

# Strength Trainer

**Owner's Manual**

*ST-FIDL*

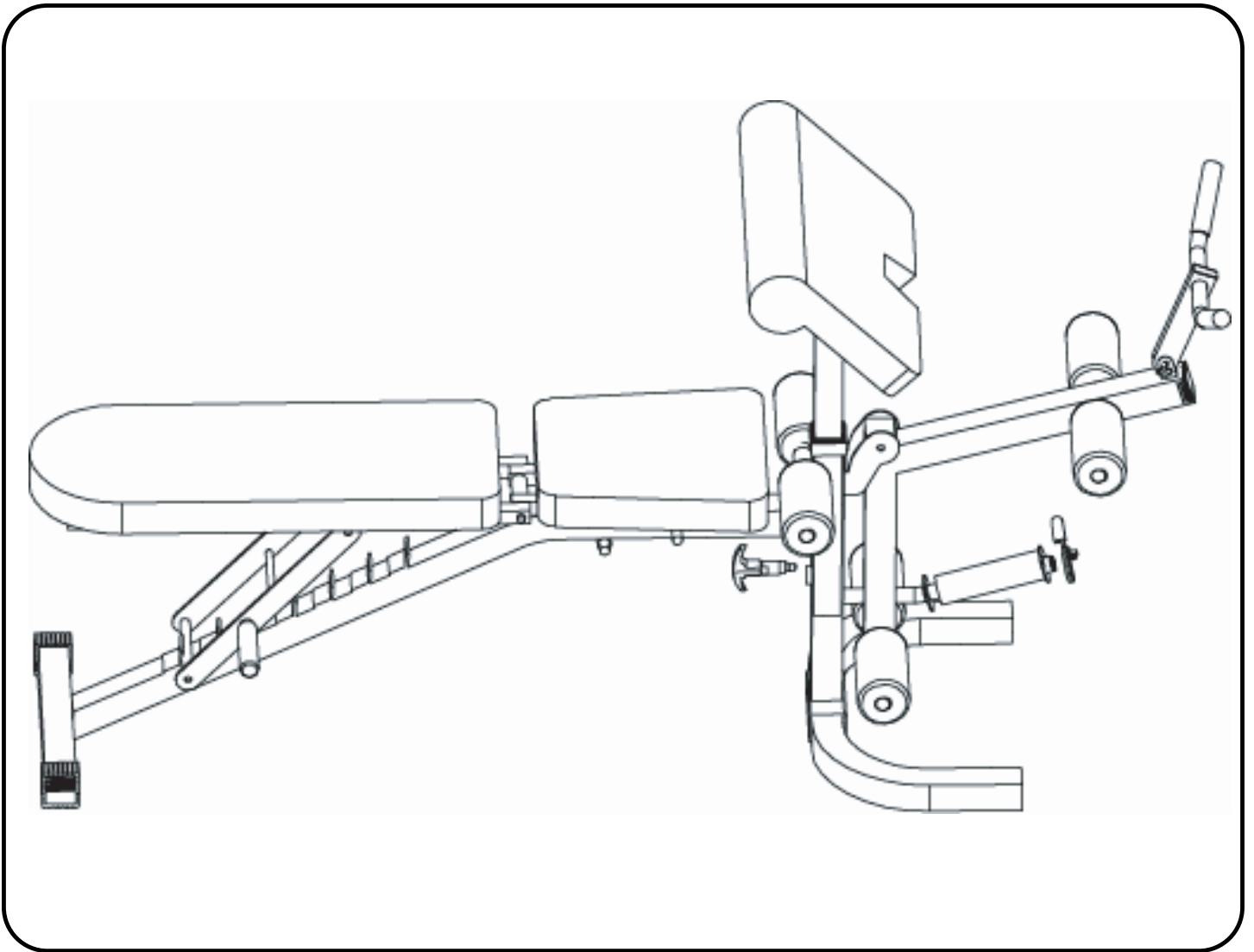

## **! CAUTION**

Read all precautions and instructions in this manual before using this equipment.

215-00001  
10/05 Rev B

---

Important Safety Information	3
Before You Start	4
Assembly	5-9
Parts List	10
Exploded View	11
Warranty Information	12

# Important Safety Information



Prior to assembly, remove components from the box and verify that all the listed parts were supplied.

**NOTE:** Hand tighten bolts and nylon nuts until machine is fully assembled.

## **SAFETY INFORMATION WARNING!**

Before using this unit or starting any exercise program, consult your physician. This is especially important for persons over the age of 35 and/or persons with pre-existing health problems. Keys Fitness Products LP assumes no responsibility for personal injury or property damage sustained by or through the use of this product.

It is the owner's responsibility to ensure that all users of this unit have read the Owner's Manual and are familiar with safety information and precautions.

## **SAFETY PRECAUTIONS**

- This Strength Trainer unit should only be used on a level surface and is intended for indoor use only. Keys Fitness recommends an equipment mat be placed under the unit to protect the floor or carpet and for easier cleaning.
- Wear comfortable, good-quality walking or running shoes and appropriate clothing. Do not use this unit with bare feet, sandals, socks or stockings!
- Always examine your unit before using to ensure all parts are in working order.
- Do not leave children unsupervised near or on the unit.
- Service to your Strength Trainer unit should only be performed by an authorized service representative, unless authorized and/or instructed by a Keys Fitness technician. Failure to follow these instructions will void the warranty.

# Before You Get Started



**THANK YOU** for making this Strength Trainer unit a part of your exercise program. Keys Fitness and our Strength Trainer Series assures the very best in value, appearance, durability and biomechanics.

This manual will guide you through the assembly process. If at any time you are having trouble with the assembly or use of this product, then please contact us at our Keys Fitness Helpline. We have trained service technicians on site to take care of you, our valued customer.

## REGISTRATION CARD

To avoid unnecessary delays in warranty parts and to insure that a permanent record of your purchase is on file with our company, be sure to send in the warranty registration card or register on-line at [www.keysfitness.com](http://www.keysfitness.com) within 10 days of purchase.

## STRENGTH TRAINER SERIES

**MODEL: ST-FIDL**

**QUESTIONS?**

**CALL**

**1-800-683-1236**

**Monday-Friday**

**8:30-5:30 Central Time**

***When calling please have the following product information available:***

**Model Name :**

**Manufactured Date :**

**PO # :**

***Model Name Decal Location***

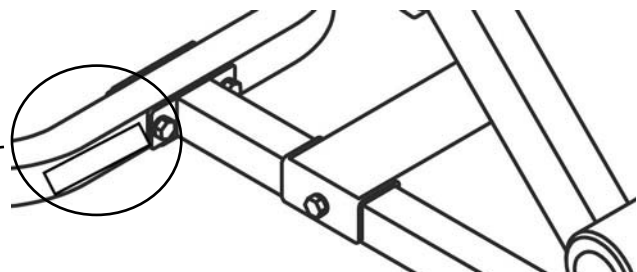

## Assembly Hardware



A4: 1PC

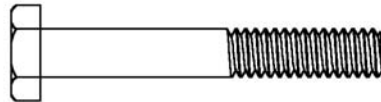

A3: 2PCS

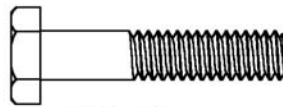

A2: 2PCS

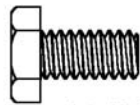

A1: 8PCS



A5: 8PCS

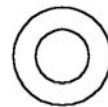

B1: 18PCS



B2: 8PCS



C1: 5PCS

## Tools Required

You will need two adjustable wrenches for assembly or M10 and M6 wrenches.

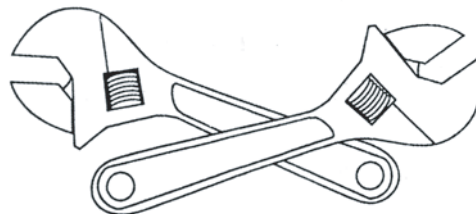

# Assembly

**NOTE: Hand tighten bolts and nylon nuts until machine is fully assembled.**

Attach U Base Frame (6) to Main Frame (5) using two Bolts (A3), four Washers (B1) and 2 Nylon Nuts (C1). Items 22 and 23 are pre-installed.

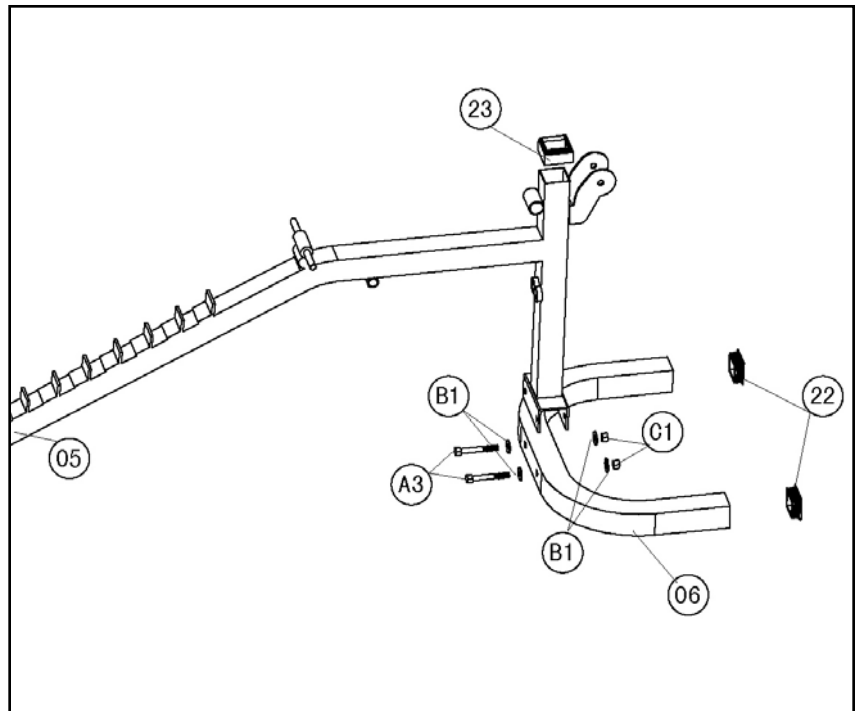

Attach the Rear Base (17) to Main Frame (5) using four Bolts (A1) and four Washers (B1). Item 18 is pre-installed.

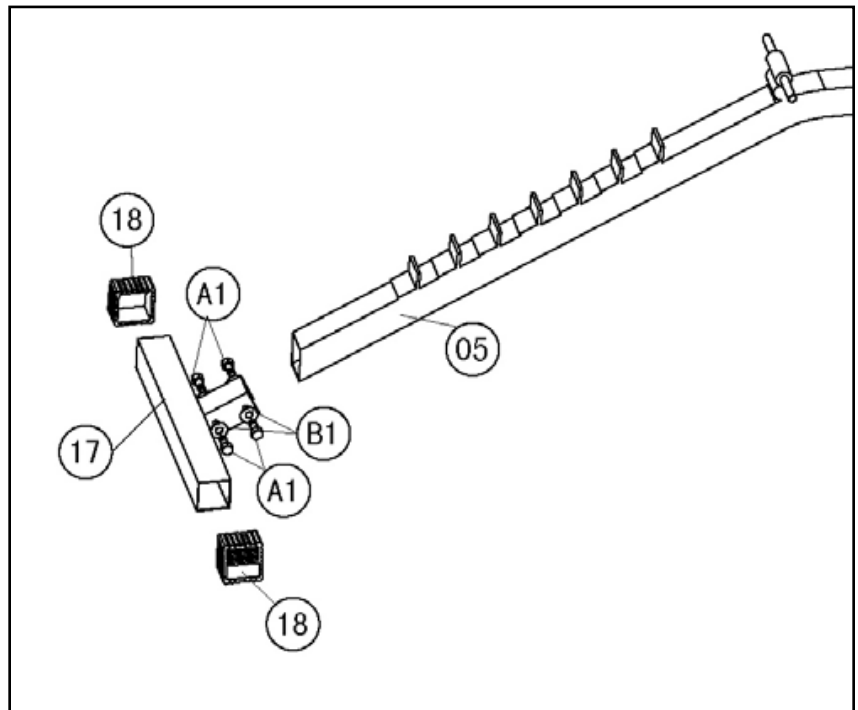

# Assembly

**NOTE: Hand tighten bolts and nylon nuts until machine is fully assembled.**

Attach Seats (2) to the two Seat Supports (15) using four Washers (B2) and four Bolts (A5). Align the holes in the Seat Support (15) with the holes in the bracket that is welded to the main frame. Slide Seat Supports onto Main Frame.

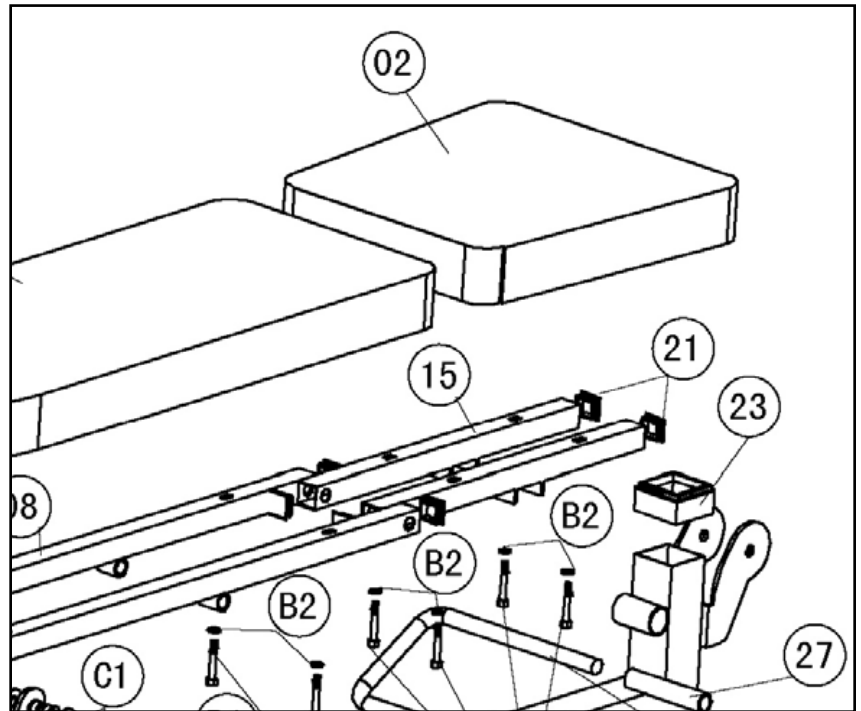

Attach one Backrest Support (8) to the pivot rod welded to the Main Frame. Push two Bushings (24) into the BackRest Support. Lift up the Backrest Support (8) to align the holes with the Backrest Adjust Bar (7). Attach with one Bolt (A2), two Washers (B1) and one Aircraft Nut (C1). Repeat for other side.

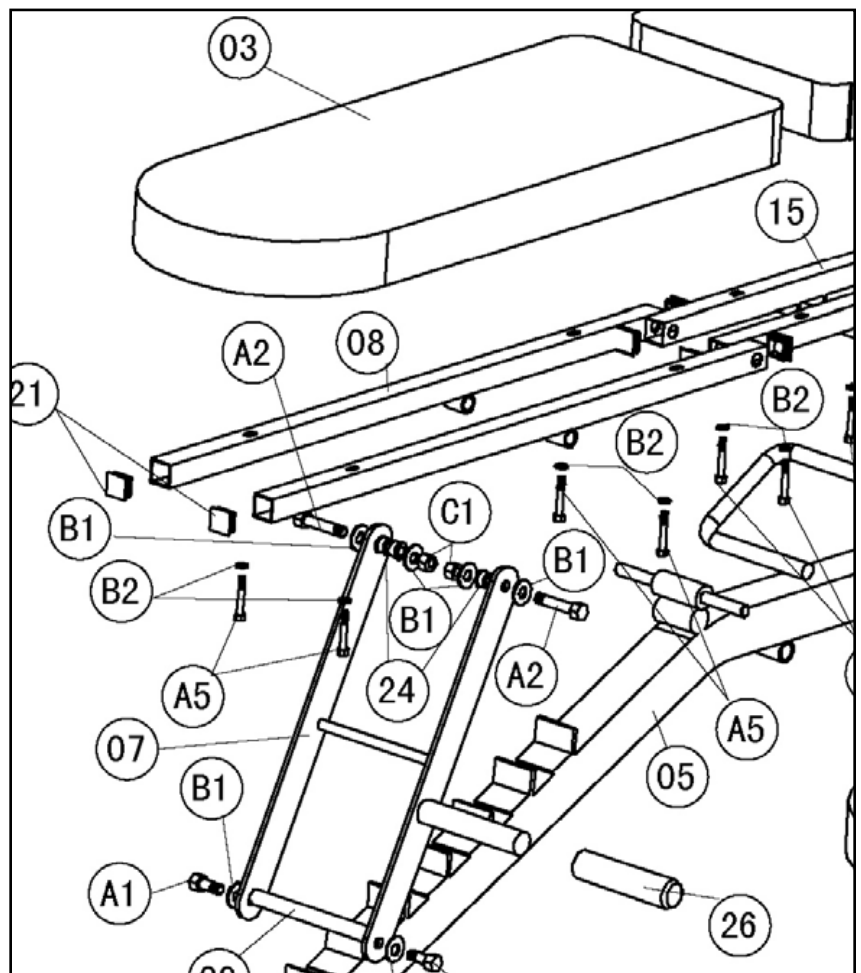

# Assembly

**NOTE:** Hand tighten bolts and nylon nuts until machine is fully assembled.

Attach the Backrest Board (3) to the Backrest Support (8) using four Washers (B2) and four Bolts (A5).

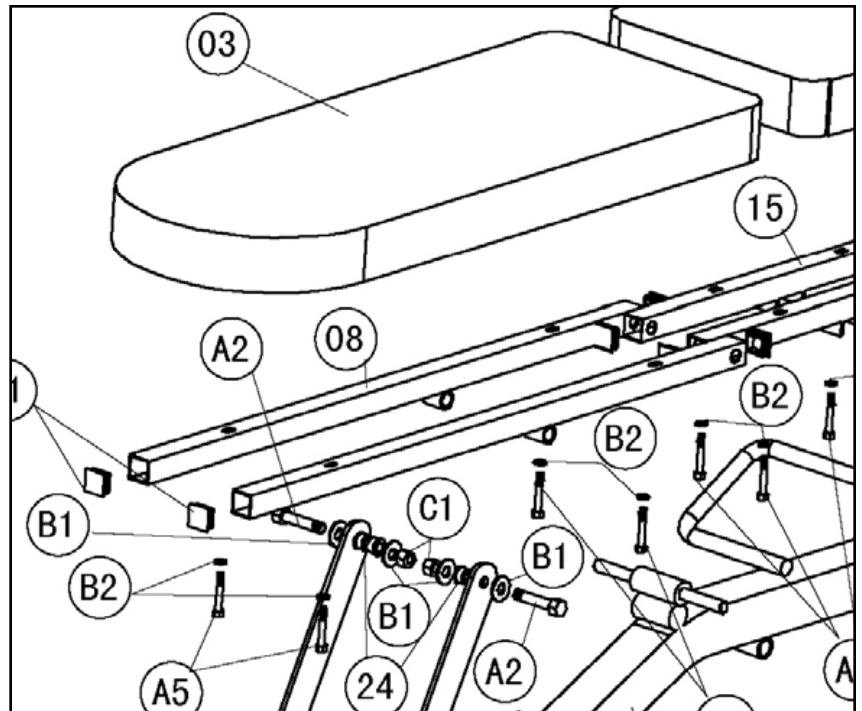

Push two Bushings (24) into Leg Developer (12). Install the Leg Developer (12) onto the Main Frame with one Bolt (A4), two Washers (B1) and one Aircraft Nut (C1).

Insert two Roller Foam Tubes (10) halfway onto Leg Developer. Push Foam Rollers (25) on each side of the Roller Foam Tube to complete Leg Developer Assembly.

Repeat this step to place Foam Roller onto Main Frame.

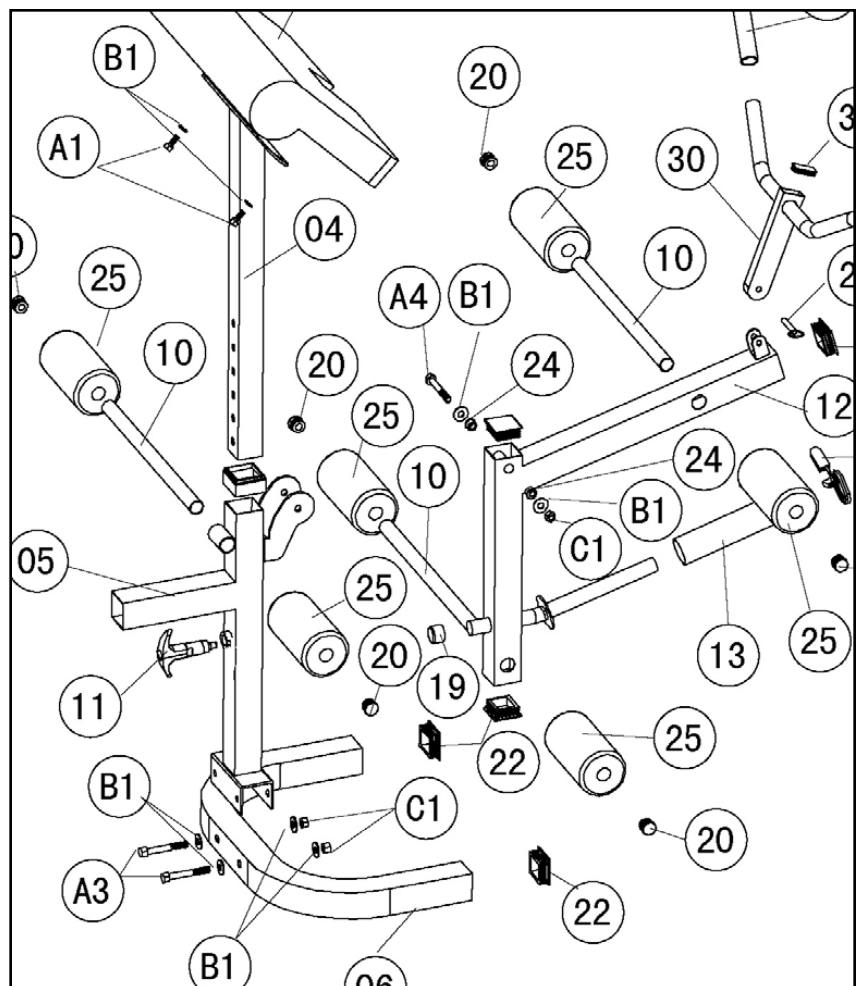



# Assembly

**NOTE:** Hand tighten bolts and nylon nuts until machine is fully assembled.

Insert Arm Curl Stand (4) into the opening at the top of the Main Frame. Secure in place using the Quick Release Pin (11).

Attach the Arm Curl Pad (1) to the top of the Arm Curl Stand (4) using two Bolts (A1) and two Washers (B1).

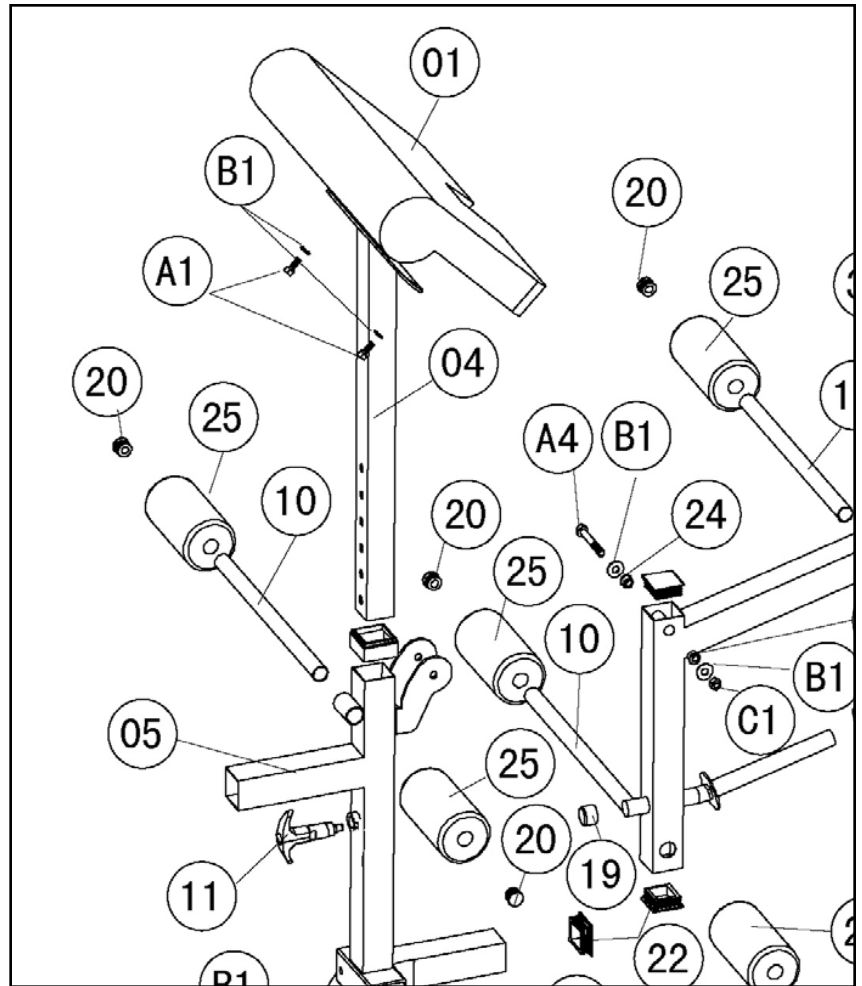

**Congratulations!!! You have completed assembly of your ST-FIDL.**

## ST-FIDL Parts List Rev B

Ref #	Part #	Description	Qty
1	228-00153	ARM CURL PAD, ST-FIDL (GREY/BLACK)	1
2	228-00154	SEAT, ST-FIDL (GREY/BLACK)	1
3	228-00155	BACKPAD, ST-FIDL (GREY/BLACK)	1
4	223-00656	ARM CURL STAND, ST-FIDL	1
5	223-00784	MAIN FRAME, ST-FIDL (SILVER)	1
6	223-00785	U SHAPED BASE, ST-FIDL (SILVER)	1
7	223-00660	BACKREST AJUSTMENT BAR, ST-FIDL	1
8	223-00657	BACKREST SUPPORT, ST-FIDL	2
9	219-00341	AXLE, M-FIDL	1
10	219-00343	ROLLER FOAM TUBE	3
11	210-00131	QUICK RELEASE PIN	1
12	223-00652	LEG DEVELOPER, ST-FIDL	1
13	210-00111	OLYMPIC SLEEVE, M-FIDL/ST-FIDL	1
14	210-00103	SPRING CLIP 1"	1
15	223-00658	SEAT SUPPORT, ST-FIDL	2
16	223-00661	SEAT ADJ BAR, ST-FIDL	1
17	223-00786	REAR BASE, ST-FIDL (SILVER)	1
18	206-00236	SQUARE END CAP 50	2
19	206-00254	ROUND END CAP 25	1
20	202-00440	ROUND PLUG 25	7
21	206-00253	SQUARE PLUG 50	8
22	206-00234	SQUARE PLUG 50	5
23	206-00235	SQUARE SLEEVE 50	1
24	202-00298	BUSHING, 10*15*10	6
25	219-00339	ROLLER FOAM	6
26	219-00342	PLASTIC HANDLE	1
27	206-00219	PROTECTIVE FOAM	1
28	210-00038	RING HEAD LOCK PIN ST-OBA/ST-FIDL	1
29	206-00170	HANDLE GRIP, M-FIDL/ST-FIDL	1
30	223-00659	ARM CURL HANDLE, ST-FIDL	1
31	206-00233	SQUARE END CAP, 20X40	6
A1	202-00296	HEX BOLT, M10X20	8
A2	202-00295	HEX BOLT, M10X50	2
A3	202-00294	HEX BOLT, M10X70	2
A4	202-00293	HEX BOLT, M10X75	1
A5	202-00173	HEX BOLT, M6*40	8
B1	202-00093	WASHER, 10	18
B2	202-00601	WASHER, D6	8
C1	202-00168	AIRCRAFT NUT, M10 M-PR	5
#	215-00001	MANUAL ST-FIDL	1

# Exploded View

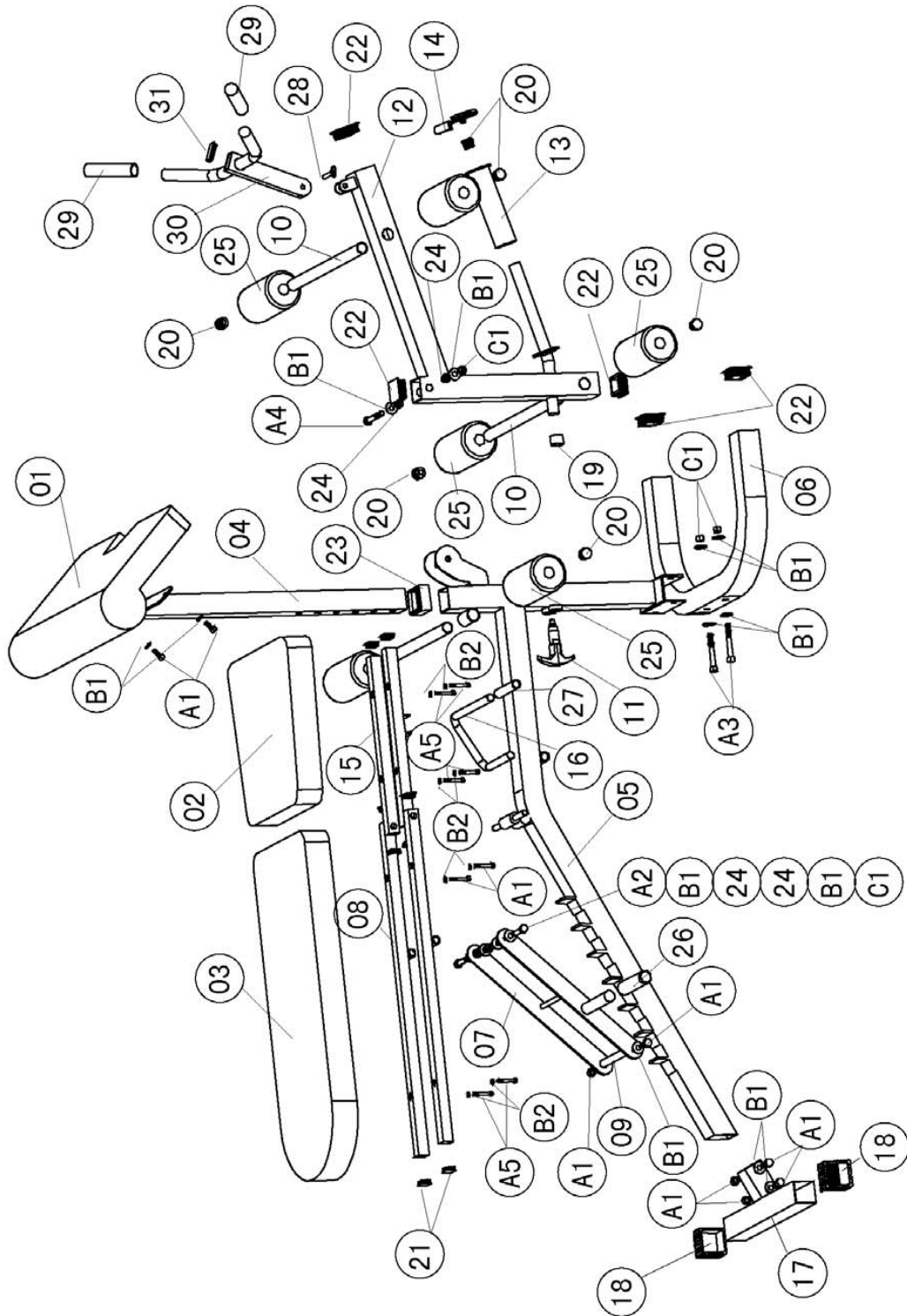

---

## **KEYS FITNESS PRODUCTS, L.P. STRENGTH TRAINER WARRANTY**

Keys Fitness Products LP warrants this product for a period of 90 days on parts and lifetime on the frame from the original date of purchase. This warranty covers the product from defects in materials and workmanship for the original purchaser. Using this product for commercial purposes, products damaged by misuse, abuse, or from shipping, moving and storage will void this warranty. Replacement parts are available from Keys Fitness Products LP.

To contact us for customer service or replacement parts, call 1-800-683-1236.

### **CUSTOMER SERVICE**

If you have any questions regarding this or any Keys Fitness product, or if we may be of assistance in any way, please do not hesitate to call our toll free number 1-800-683-1236.



**Keys Fitness Products, L.P.**  
**4009 Distribution Drive, Suite 250**  
**Garland, Texas 75041**  
**Customer Service: 1-800-683-1236**